



# September-October 2002



Member of the  
National Federation  
of High Schools



A Proud Member of  
The High School Internet Network

**FROM THE DESK OF...  
THE EXECUTIVE DIRECTOR**

**F**rom time to time, the Rhode Island Interscholastic League office receives calls seeking clarification of whether volunteer or unpaid coaches need to be state certified in order to coach. In checking with the R. I. Department of Education, it is their position that *all* coaches - paid or unpaid - who interact with student-athletes as coaches *must* be certified by RIDE.

I urge all Principals to be certain that all coaches in your school are certified before allowing them to coach. This includes anyone serving in the capacity of a paid, unpaid, and/or volunteer coach. I also recommend that *all* coaches on your staff be appointed by the people in your [school] system whose responsibility it is to select people to positions such as coaching. Both of these issues - certification and appointment - are liability issues.

The League office has received many complaints by soccer officials this season regarding the lack of supervision at soccer games - boys and girls. In some instances, the crowds are too close to the field and spend most of the time heckling the officials. When officials leave the field following the game, the spectators continue with negative, derogatory remarks directed at the officials. While all officials are used to negative comments, they are concerned about the venom in the [spectators'] words. Game Supervisors can be very helpful in controlling and preventing the kind of behavior that should not be allowed in RIIL contests. Given the nature of today's society, we need to protect our players, coaches, and officials from hostility.

Additional complaints from the officials regarding soccer are the lack of a game clock, a timer, a signaling device which is used to signify substitutions, and ball holders.

Your attention to these very important issues is greatly appreciated. Only by working together can we continue to provide the quality programs that we offer for the student-athletes we serve.

\* \* \* \* \*

**DIRECTOR OF BOYS' SOCCER**

The RIIL is looking for a person who may be interested in serving as Director of Boys' Soccer. The person must be a Principal, Assistant Principal, or School Administrator who has knowledge of soccer and wants to become involved in the League.

If you are interested, please contact Mr. Lynch at the League Office, 272-9844 or by email at [info@riil.org](mailto:info@riil.org).

**PRINCIPALS AND ATHLETIC DIRECTORS  
WORKSHOP**

**T**he RIIL 6<sup>th</sup> Annual Principals/Athletic Directors Workshop that was held on Thursday, September 19, 2002 was well attended and resulted in a very positive response from those who participated.



*Participants at the  
6<sup>th</sup> Annual Principals/Athletic Directors Workshop*

In an effort to better serve our member schools, the RIIL sent out an evaluation form asking for input on the day's events and suggestions for future workshops. Overall, [evaluation] responses indicate that the topics reviewed were timely and relevant. Several recommendations were submitted which will be taken into consideration for future workshops.

The guest speaker was Col. David Gavigan, who is a nationally and internationally recognized specialist in school violence [and terrorism]. He addressed the gathering on the topic of hazing and ways in which to counter school violence. While some evaluation returns indicate that the presentation was lengthy, general consensus indicates that the information he provided was well received.



*Col. David Gavigan addresses the gathering of  
Principals and Athletic Directors*

The RIIL administration and staff sincerely hopes that you walked away from the day with helpful information that you can use in the day-to-day operation of your school(s).

\* \* \* \* \*

**REMEMBER WHEN ...?**

**E**ach year, the staff at Beloit College (Wisconsin) puts together a list to try to give the faculty a sense of the mindset of the year's incoming freshmen. Here is the list from 2001:

- The people who started college in Fall 2001 across the nation were born in 1983. What were you doing in 1983?
- Their lifetime has *always* included AIDS.
- They are too young to remember the space shuttle blowing up.

- Bottle caps have always been screw off and plastic and did not require the requisite household item - a bottle opener.
- The CD was introduced the year they were born.
- They have always had an answering machine.
- They have always had cable television.
- They cannot fathom not having a remote control
- Jay Leno has always been on The Tonight Show.
- Popcorn has always been cooked in a microwave.
- They never took a swim and thought about Jaws.
- They can't imagine what hard contact lenses are.
- They don't know who Mork was or where he was from.
- They never heard: "Where's the Beef?", "I'd walk a mile for a Camel", -or- "de plane, Boss, de plane".
- They do not care who shot J.R. and have no idea who J.R. even is.
- McDonald's never came in Styrofoam containers.
- They don't have a clue how to use a typewriter.

\*\*\*\*\*

→ **IMPORTANT NOTICE** ←

### *Changes for Pole Vault Landing Pad*

**F**or the past eighteen (18) months, NFHS and ASTM have worked to establish industry standards for high school pole vault landing systems. They now have final dimensions and a diagram for state association reproduction and distribution (*see diagram - last page of this bulletin*).

***The minimum dimension for the overall footprint of the new landing system measures 20'2" from front to back. The minimum standard coincides with the ASTM standards recommended for high school landing systems.***

**THIS NEW MINIMUM SIZE IS EFFECTIVE IMMEDIATELY.**

The NFHS track and field rules committee recommended changes regarding the pole vault landing pad, specifically enlarging the size of the landing pad. **This is now a requirement for the 2003 track season.** The new requirements are:

1. Minimum width of the pad to be 19'8"
2. Minimum length of the pad to be 20'2" from the front edge of the vaulting box to the back of the pad. There must be 16'5" of landing pad behind the vault box.
3. The height (or thickness) of the landing pad to be a minimum of 26".
4. A collar be placed around the vault box to help minimize injuries by vaulters falling into the box.

Upgrades to existing landing pads may be possible. The height of the upgrade would need to be the same as the existing pad, must be connected to the main pad, and all seams covered so the vaulter cannot fall through the crack and strike the ground. **The common cover must cover the entire landing pad.**

\*\*\*\*\*

### **VOLUNTEERS NEEDED**

**M**ajor League Soccer's National Championship, the MLS Cup, is coming to Providence. Providence was named the Host City for the 2002 MLS Cup game to be held at Gillette Stadium on October 20, 2002. There are several duties and schedules that are available. If you are interested, or know of anyone who might be, please contact the RIIL office. We will be happy to fax you description/schedule of volunteer duties available. For more information re: the MLS Cup and volunteer program, contact:

Kerry Emmons, Director  
 Events & Operations  
 R. I. Sports Council  
 Tel: 401.521.5000  
 Fax: 401.751.2434  
 email: [Kemmons@provchamber.com](mailto:Kemmons@provchamber.com)

\*\*\*\*\*

*"Here is Edward Bear; coming down stairs now; bump, bump, bump, on the back of his head, behind Christopher Robin. It is, as far as he knows, the only way of coming down stairs, but sometimes he feels there really is another way, if only he could stop bumping for a moment and think about it."*

Winnie the Pooh

\*\*\*\*\*

### **DATING VIOLENCE: IT IS YOUR BUSINESS**

**O**ctober is Domestic Violence Awareness Month. A new study released in the Journal of the American Medical Association finds that one in five female high school students reports being physically or sexually abused by a dating partner. In the League's ongoing efforts to work together with the Rhode Island Coalition Against Domestic Violence to promote awareness of teen dating violence, we offer the following as an installment in a continuing series of articles addressing the very important issue of teen dating violence. If you have any questions or would like more information on this subject, we encourage you to contact the Coalition at (401) 467-9940 - or - 1-800-494-8100 - or - any one of its member agencies in your area.

### **Warning Signs of Abuse in Teen Dating Relationships**

How do you know when a teen might be in an abusive relationship, especially if s/he says the relationship is okay? Most of the time, violence happens when the couple is alone. You might not see physical signs or abuse like bruises or red marks. It's hard to know how to recognize a teen in trouble, but there are some signs to look for. Consider the warning signs listed below, and ask yourself these questions:

- ***Name-calling and put downs.***  
 Does one teen in the relationship call the other names?  
 Does s/he use insults to put the other person down?

*"I was insulted, accused of crazy things, humiliated and had my mind twisted. I was constantly criticized and called names. I was put down, no, verbally attacked for things that were not a problem the day before. I was blamed for everything that went wrong. Often, I had no idea what was wrong."*  
Sandy, 18

▪ **Extreme Jealousy**

Does one teen in the relationship act incredibly jealous when the other talks to peers? Does s/he accuse their girlfriend or boyfriend of flirting even when it's an innocent conversation?

*"We spent all our time together. It was wonderful at first, but it became obsessive. At one point, I even had to be on the phone with him when I went to sleep so that he knew I was home at night. I was allowed to talk to only two people at school - both were girls - and he had his friends watch me to make sure I was obedient."*  
Salina, 13

▪ **Making Excuses**

Does one teen in the relationship make excuses for the other? Does s/he have to apologize for the other person's behavior?

▪ **Canceling or Changing Plans**

Does s/he cancel plans often, and at the last minute? Do the reasons make sense or do they sound untrue?

▪ **Monitoring**

Does one teen call, page or check up on the other constantly? Does s/he demand to know the other person's plans?

Does s/he need to know who the other person was with?

▪ **Uncontrolled Anger**

Have you seen one person lose his/her temper? Does that person throw things - or break things - when s/he is angry? Does one teen worry a lot about upsetting the other?

▪ **Isolation**

Has one teen in the relationship given up spending time with friends? Has s/he stopped doing activities that used to be important?

*"I couldn't talk to another boy ... He resented my girlfriends and my family. He said, 'All we need is each other.' If he chose to go out with his friends or not bother to call me, I was supposed to sit at home and wait for him to call. If I wasn't there, I was interrogated over and over about where I was, who I talked to, even what I wore ... I became more and more isolated, more dependent ... and more afraid of [his] temper if I didn't do what he wanted."*

Jill, teenager

▪ **Dramatic Changes**

Has the teen's appearance changed? Has s/he lost or gained weight? Have her/his grades dropped? Does the teen seem depressed?

*"I emotionally abused her by telling her one thing and doing the opposite. I controlled her dress, behavior and who she could be friends with. I used my gang to intimidate her by pointing out victims and threatening to do the same to her."*  
Ruiz, 17

▪ **Injuries**

Does the teenager have unexplained injuries, or does s/he give explanations that don't make sense?

▪ **Quick Progression**

Did the relationship get serious very quickly?

*Adapted from: (2000). "What You Need to Know About Dating Violence: A Teen's Handbook." Liz Claiborne*

*Quote source: Levy, Barrie. (1993). In Love & In Danger. Seal Press*

**NEXT MONTH:** What to do if you suspect there's a problem.

\* \* \* \* \*

**PRE-CONTEST ANNOUNCEMENT  
PROMOTES GOOD SPORTSMANSHIP**

**G**ood sportsmanship is vital to the educational integrity of interscholastic activities. With that in mind, the following is presented as a possible pre-game announcement for any interscholastic contest during the school year.

"Activity programs at \_\_\_\_\_ High School are primarily

for student participants. The PURPOSE of these activities is to provide a positive learning experience and the opportunity for personal growth for those participating.

We are pleased to host as our guests this (afternoon/evening) \_\_\_\_\_ High School.

This competition is being conducted according to the rules of the Rhode Island Interscholastic League and the National Federation of State High School Associations.

Cheerleaders, officials and spectators can – and are expected to – assist in the promotion and achievement of good sportsmanship by taking personal responsibility for keeping this and all interscholastic contests at a high level of fair, clean, wholesome competition."

\* \* \* \* \*

*"Everyone is a prisoner of his own experiences. No one can eliminate prejudices - just recognize them."*

Edward R. Murrow

\* \* \* \* \*

**LISTENING TO SCHOLAR-ATHLETES:  
SPORTSMANSHIP IN HIGH SCHOOL ATHLETICS**

"Do you think that you can move your marker a little to the right for me?" asks Joe.

"Sure, no problem," replies Sam. "Is that enough?"

"Yeah, that's great. Thanks," says Joe. Then he lines up and drains his putt as Sam stands quietly out of the way.

"Good putt", utters Sam even though that putt had been for birdie and now Joe is beating him by a stroke.

Sportsmanship is an essential part of high school athletics, but in recent years trash-talking, unsportsmanlike penalties and technical fouls have seemed to become commonplace. Competition in sports is great and not to be discouraged in any way; however, competitiveness does not need to translate into cheating, humiliating an opponent, or being derogatory to officials. This type of unacceptable behavior is like cancer in every sport, instigated by participants and spectators alike. Competition will always be a huge part of sports, but sportsmanship should never be forgotten even in the heat of battle.

Golf is a great example of how competitive players can still be polite and even friendly with their opponents. Etiquette is probably the first thing that any golfer learns: be quiet while someone else is hitting, help opponents look for lost balls, congratulate others on good shots, tend the pin when asked, and never steal "honors". These rules are unwritten, but every golfer knows that they are more important than any in the rule book. The amazing thing about golf is that no one watches to make sure the players follow the rules. The full responsibility of playing honestly rests on each individual. Even more amazing, players rarely take advantage of this and break the rules! Basketball, football, baseball, even volleyball have some kind of rules official to watch and make sure that no rules are broken. These officials are constantly catching people trying to break rules and penalizing them. All the while fans in the stands yell how horrible the officials are. This should not happen.

As kids get older and the sports become more and more competitive, the one thing that everyone - players, parents, and fans - need to remember is that these sports are still being played for enjoyment. Sure, it is more fun to win than to lose, but when that victory comes along with kids trash-talking, fan yelling obscenities at refs, and parents angry at coaches, where is the fun? The reason that I personally loved playing golf at the high school level was that in every match I would play with at least two other kids that I had never met before. For two hours we would talk, joke and compete. By the time we came to the last hole, we were friends. Don't get me wrong - I still put all of my effort into beating them as badly as possible. It was just that we knew there was no need to hate each other just because we were on opposing teams.

*Steve Gisel  
Midland Bullock Creek (Michigan)*

\* \* \* \* \*

### YOU WANT ME TO DO WHAT ???

Workers were asked to submit quotes of things said by their supervisors that were difficult to understand and/or follow. Here are the Top 10 finalists:

1. "As of tomorrow, employees will only be able to access the building using individual security cards. Pictures will be taken next Wednesday and employees will receive their cards in two weeks." (*This was the winning quote from ... Microsoft Corp. in Redmond, WA*).
2. "What I need is an exact list of specific unknown problems we might encounter." (*Lykes Line Shipping Co.*)
3. "Email is not to be used to pass on information or data. It should be used only for company business." (*Electric Boat*)

4. "This project is so important, we can't let things that are more important interfere with it." (*U.P.S.*)
5. "Doing it right is no excuse for not meeting the schedule." (*Delco Corp.*)
6. "No one will believe you solved this problem in one day! We've been working on it for months. Now ... go act busy for a few weeks and I'll let you know when it's time to tell them." (*3M Corp.*)
7. "Teamwork is a lot of people doing what I say." (*Quote from the boss ... Citrix Corp.*)
8. My sister passed away and her funeral was scheduled for Monday. When I told my boss, he said she died on purpose so that I would have to miss work on the busiest day of the year. He then asked if we could change her burial to Friday. He said, "That would be better for me." (*FTD Florist*)
9. "We know that communication is a problem, but the company is not going to discuss it with the employees." (*AT&T Long Lines Division*)
10. One day my boss asked me to submit a status report to him concerning a project I was working on. I asked him if tomorrow would be soon enough. He said, "If I wanted it tomorrow, I would have waited until tomorrow to ask for it!" (*Hallmark Greeting Cards*)

\* \* \* \* \*

### LYING IS LIKE RECKLESS DRIVING

Sometimes lying makes our lives easier. If you want the day off, just call in sick. If your boss asks if you've finished a report, say you left it at home. And if an irate customer calls, just make up a good cover-up story. Sure, technically these are lies, but since no one is hurt, what's the big deal?

We tell ourselves these sorts of lies are harmless. But are they really? Telling lies is like drunk driving. If we're lucky, we won't get caught and no one will get hurt. Still, drunk driving is wrong because it's irresponsible to recklessly endanger human life. Most lies are wrong because they recklessly endanger human relationships. What's more, lies are habit forming - the more lies we tell, the easier it becomes, so we tell more lies.

Self-serving lies that help us get out of a jam or look better are like land mines. Many of them may lay dormant, but sooner or later some of them will explode, damaging both credibility and reputation. The ethical duty to be worthy of trust does not bend to our needs, convenience or desire to avoid unpleasant consequences. Besides being dishonest, lying is disrespectful because it deprives the victim of true information needed to make sensible decisions.

Lies damage personal and business relations because they generate suspicion and distrust. Once lied to most people think, "What else will he lie to me about?" This is not a healthy basis for any relationship.

*From Character Counts  
Josephson Institute of Ethics (CA)*

\* \* \* \* \*





## SUMMARY OF MEETINGS

The following is a summary of the August 16, 2002 *and* September 16, 2002 meetings of the Principals' Committee on Athletics.

The August meeting of the Principals' Committee on Athletics was called to order at 1:40 pm

### EXECUTIVE DIRECTOR'S REPORT

The Executive Director's Report was approved.

### TREASURER'S REPORT

The Treasurer's Report was approved.

### COMMUNICATIONS

Mr. Lynch referred to several memoranda and publications that were placed in member's folders or filed in the League office.

### RESIGNATION

David Light submitted his resignation as a member of the Principals' Committee on Athletics and as Co-Director of Boys' Basketball. On a motion made and seconded, the Committee on Athletics accepted, with regret, Mr. Light's resignation.

Mr. Lynch reported that there are two (2) vacancies on the Committee as the result of Mr. Light's resignation and Mr. Mercurio's resignation (June '02). Mr. Lynch stated that he has received letters from administrators of member schools who have expressed interest in serving on the Principals' Committee on Athletics. Mr. Lynch will meet with the interested parties to determine where their qualifications will best serve the Committee.

### FOOTBALL

**Mr. James Murano**

Mr. Murano reported that there will be a meeting of all football coaches and captains on Tuesday, August 27, 2002 at North Kingstown H.S. He noted that this is a change from the meeting that was originally scheduled on Monday, August 26<sup>th</sup>. Representatives from the R. I. Football Officials Association and medical personnel will be present. In addition, a video will be shown about sports injuries.

In other business, Mr. Lynch reported on a request from a student-athlete at Middletown High School who plays an offensive tackle position. He is seeking permission to wear #92, the number of a friend who passed away last Spring. Insofar as #92 is designated for defensive players, this issue was brought before the Committee.

On a motion made and seconded, the Principals' Committee on Athletics unanimously approved the request for this year only.

### SOCCER

**Mrs. Kathryn Crowley**

Mrs. Crowley stated that everything is in place for the beginning of the 2002-2003 girls soccer season. She reported that Kevin McNamara, Director of Athletics at Lincoln H.S., will serve as an Assistant Director of Girls Soccer.

Mr. Lynch reported that Victor Mercurio, who resigned as Director of Boys' Soccer in June 2002, will continue to oversee the boys soccer program until a new boys' soccer director is appointed.

Mr. Lynch also reported that there is a meeting for all boys' soccer coaches and captains on Tuesday, August 27, 2002 at the League office.

### TENNIS

**Mrs. Denise Boulé  
Ms. Candace Caluori**

Mrs. Boulé, Director of Girls Tennis, reported that there is a revised meeting schedule for girls' tennis that will be sent to all participating schools.

### VOLLEYBALL

**Mr. Donald Kavanagh  
Ms. Elaine Botelho**

Mr. Kavanagh, Director of Boys Volleyball, reported that he sent a survey to all participating schools regarding the change of boys volleyball from Fall to Spring. He is receiving responses to that survey and will report back to the Principals' Committee on Athletics at a future meeting.

### FIELD HOCKEY

**Ms. Jean Angell**

Ms. Angell reported that everything is in place for the beginning of the 2002-2003 girls' field hockey season

### CROSS COUNTRY

There was no report in Cross Country at this meeting.

### BASKETBALL

**Mr. Gerald Foley  
Ms. Cindy Neal  
Ms. Colleen Gribbin**

Mr. Magarian submitted the 2002-2003 Girls Basketball Schedule for the Committee's review and consideration.

On a motion made and seconded, the Principals' Committee on Athletics unanimously approved the 2002-2003 Girls' Basketball Schedule, to include the All-Star Game scheduled for Sunday, March 16, 2003.

In other business, Mr. Lynch reported that he has met with representatives from the Convocation Center at the University of Rhode Island to discuss the possibility of holding the RIIL State High School Basketball Championships at that site. Mr. Lynch stated that initial figures indicate an approximate loss of \$8,000 if the event is moved to URI because [URI] will charge a \$2.00/ticket surcharge. The Dunkin' Donuts Center (formerly the Providence Civic Center) where the event has been held for several years, does not charge the surcharge amount (\$2.00/ticket).

A site for the championships will be discussed by the Joint Boys and Girls Basketball Committee at its next meeting and Mr. Lynch will report the findings to the Principals Committee on Athletics.

**FASTPITCH SOFTBALL** **Mrs. Elizabeth Marquis**

Mrs. Marquis submitted the following 2001-2002 Fastpitch Softball Championships for the Committee's review and consideration:

**Division Championships**

I-North	Lincoln High School
I-South	Chariho High School
II-East	Tiverton High School
II-West	Johnston High School

**State Championships**

Division I	North Kingstown High School
Division II	Tiverton High School

On a motion made and seconded, the Principals' Committee on Athletics unanimously approved the 2001-2002 Fastpitch Softball Championships as submitted.

Mrs. Marquis reported that the 2001-2002 season was a very good one with an increased level of play from past years. She stated that there are three (3) new teams joining the RIIL fastpitch softball league that may necessitate a new alignment - possibly changing to three (3) divisions.

**SLOWPITCH SOFTBALL** **Mr. Tony Torregrossa**

Mr. Lynch reported on violations of the RIIL Rules and Regulations by the Cranston High School East slowpitch softball team and a letter from Donald Frederick, Principal of CHSE, in response to same. The violations were as follows: a student-athlete from the CHSE slowpitch softball team participated in a town league while playing for the school team; and, the CHSE slowpitch softball team voluntarily forfeited two (2) games during the 2001-2002 season.

The Principals' Committee on Athletics commended Mr. Frederick for internally addressing the issues and taking the necessary steps to avoid that the same infractions happen again.

On a motion made and seconded, the Principals' Committee on Athletics voted 11-1, with 1 abstention, to place the Cranston High School East girls slowpitch softball program on probation for one calendar year, beginning on June 15, 2002. If another forfeit/cancellation occurs during the 2003 season, the team will not be allowed to participate in any post-season play. In addition, the probation will be extended and/or the team will be subject to any other penalties as voted by the Principals' Committee on Athletics.

**LACROSSE** **Mr. George Finn**

Mr. Finn reported on the issue concerning Lincoln High School's membership in the RIIL boys' lacrosse league. During the last (2001-2002) season, Lincoln H.S. competed against RIIL member schools as part of the 2001-2002 RIIL boys lacrosse schedule. However, in a letter from Mr. Frederick Silva, Principal, Lincoln H.S., it was stated that the Lincoln H.S. boys lacrosse team entered the season as a club

team with the permission of the Principal and the Superintendent of Schools. The lacrosse program was never voted on by the Lincoln School Committee to be a sanctioned and funded program at the high school.

On a motion made and seconded, the Principals' Committee on Athletics voted 7-4, with 1 abstention, to not include Lincoln H.S. in the RIIL boys lacrosse schedule for the 2002-2003 season. However, Lincoln H.S. may contact other RIIL [member] teams to schedule non-league games.

**GOLF** **Mr. John Gray**

Mr. Gray addressed the issue of four (4) separate forfeits by North Smithfield H.S. during the 2001-2002 season. The forfeits did not come to Mr. Gray's attention until the season had ended. One of the forfeits was because of a mix-up with the bus schedule that resulted in no bus being available. The others were the result of not having enough players to participate in the scheduled matches.

Mr. Lynch received a letter from Mr. Steven Knowlton apologizing for the incidents and assurance that the situation will be addressed so that similar occurrences do not take place next season.

On a motion made and seconded, the Principals' Committee on Athletics voted 10-2 to place the North Smithfield High School golf team on probation for one calendar year beginning on June 15, 2002. If another forfeit/cancellation occurs during the 2003 season, the team will not be allowed to participate in any post season play. In addition, the probation will be extended and/or the team will be subject to any other penalties as voted by the Principals' Committee on Athletics.

It was further noted that the more severe penalty would have been imposed if the League had been made aware of the first, and subsequent, forfeitures when they occurred.

In other business, Mr. Gray reported that the Golf Committee will meet later in the Fall to discuss the possibility of forming a separate girls' golf league.

**OUTDOOR TRACK** **Mr. Robert Littlefield**

Mr. Lynch reported that the [outdoor track] coaches met at the end of the 2001-2002 season. Several recommendations were proposed to the RIIL. These recommendations have been referred to the Track Committee. Mr. Littlefield will report back to the Principals' Committee on Athletics.

**HOCKEY** **Mr. Daniel Sheehan**

Mr. Sheehan reported that of the nine (9) rinks that provide ice time for the RIIL high school hockey schedule, only one (1) has not yet submitted available dates for the 2002-2003 season. The Principal of Burrillville High School is scheduled for a hearing later in this meeting to appeal the Committee's previous denial of Burrillville High School's request to move from the Met A Division down to Met B. Once a decision is reached, Mr. Sheehan will proceed with the 2002-2003 schedule.

Mr. Lynch addressed the issue of rink guarantees, which is presently \$600.00/night. Several rink managers have

contacted the League office to express their concerns that the existing guarantee is not enough to cover the expenses of making the rink(s) available for the RIIL high school hockey program. Mr. Lynch proposed increasing the rink guarantee amount to \$700.00 per night.

On a motion made and seconded, the Principals' Committee on Athletics unanimously approved increasing the rink guarantee to \$700.00 per night.

In other business, Mr. Lynch reported on the status of the RIIL girls' hockey program. He stated that the RIIL will develop a schedule and pay for expenses for the new girls hockey program. This will eliminate a cost to schools for ice time and officials.

Mr. Lynch proposed a fee of \$900.00 to schools participating in the RIIL girls' hockey league. In the case of co-op teams, it is anticipated that the schools would split the fee. Although the proposed \$900.00 fee will not fully cover all the expenses incurred in running this program, Mr. Lynch stated that he is hoping to secure sponsor monies for the hockey program.

On a motion made and seconded, the Principals' Committee on Athletics unanimously approved a \$900.00 fee for all schools participating in the RIIL girls' hockey program.

Mr. Lynch recommended that the girls hockey program adhere to the same game cap as the boys hockey program, which is twenty-four [24] games. He also proposed that November 4<sup>th</sup> be the first day of authorized practice for the girls' hockey program. The starting date for all [other] winter sports, including the boys hockey program is November 20<sup>th</sup>. However, because it is a new sport and the players have little or no experience in hockey, the earlier date will allow for adequate practice/condition time due to the limited availability of ice time for the girls' hockey program.

On a motion made and seconded, the Principals' Committee on Athletics unanimously approved a cap of twenty-four (24) games and a starting date of November 4<sup>th</sup> for the RIIL girls hockey program.

#### **WINTER SCHEDULES / INTERPRETATION MEETING DATES**

- **Gymnastics**

Mr. Richard Stapleton, Director of Girls' Gymnastics, addressed several issues that were discussed by the Gymnastics Coaches Association, including championship format, use of vaulting tables, and problems with scheduling because of availability of sites and the number of qualified judges. These topics will be placed on the agenda for the September meeting of the Principals' Committee on Athletics. In addition, Mr. Stapleton will submit the 2002-2003 gymnastics schedule at the September meeting for the Committee's review and consideration.

- **Wrestling**

Mr. Lemoi submitted the 2002-2003 Wrestling Schedule for the Committee's review and consideration. He noted the following: LaSalle Academy moved from Class B to Class A-2; South Kingstown H.S. moved from Class A to B-1; and Mt. Hope H.S. moved from Class B to Class C-

1. He also stated that Tolman H.S. has joined the RIIL wrestling league and has been placed in Class C-2.

On a motion made and seconded, the Principals' Committee on Athletics unanimously approved the 2002-2003 Wrestling Schedule.

Mr. Lemoi also reported that the Wrestling Coaches Mandatory Interpretation Meeting will be held on Wednesday, October 16<sup>th</sup>, 7:00 pm at Cranston High School West.

#### **SPORT OFFICIALS ASSIGNORS FEE PROPOSAL**

Mr. Lynch reported on a fee scale that would provide a stipend for the assignor from each sport officials association. The fee reflects \$2.00/per assignment based on one-half the number of allowed games in each sport; i.e., boys' soccer has a cap of twenty-two (22) games. Therefore, each school participating in boys' soccer will be charged for 11 games x \$2.00 for a total of \$22.00. To compensate the assignors for playoff assignments, each school will be charged \$2.00 for each sport that requires officials; i.e., if a school has ten (10) sports that require assignments, it will be charged 10 x \$2.00 for a total of \$20.00. The assignors' fees will be added to the Membership Dues and Fees invoice that is sent to each school at the start of the school year.

Every school was notified last year to allow at least \$1,000.00 in their budgets for this expense. Mr. Lynch noted that in all cases, the figure is considerably less than \$1,000.

On a motion made and seconded, the Principals' Committee on Athletics unanimously approved the proposed assignors' fees.

#### **RIIL HALL OF FAME**

Mr. Lynch reported that the newly created RIIL High School Athletic Hall of Fame will induct its first class on April 30, 2003. He stated that the Hall of Fame Committee shall be comprised of twelve [12] voting members and that the following vacancies still exist: two representatives from the Principals' Committee on Athletics; two representatives from the Athletic Directors' Association, and one representative from the Superintendents Association. In addition to the voting members, Mr. Lynch, Mr. Magarian and Mrs. Brown will sit on the Hall of Fame Committee.

Mr. Lynch stated that the deadline for submission of applications is October 1<sup>st</sup> and emphasized the necessity to fill the vacancies on the Hall of Fame Committee so that the Committee will be in place and ready to review the applications as they are submitted.

#### **REPORT OF JOINT COMMITTEE OF PRINCIPALS AND ATHLETIC DIRECTORS**

Mr. Lynch submitted a survey to be sent to all member schools regarding a proposed amendment to Article 7, Section 7c - Non-School Competition, which would allow a student-athlete to participate/compete as a member of a non-school team in organized non-school competition in the same sport or

other sport provided there is no conflict with his/her high school team's practice/competition.

A lengthy discussion ensued regarding the possible ramifications of the proposed change to the existing rule.

On a motion made and seconded, the Principals' Committee on Athletics unanimously voted to have Mr. Lynch address the aforementioned rule at the September 19<sup>th</sup> meeting of all Principals' and Athletic Directors for their feedback and report back to the next meeting of the Committee. At that time, the Committee will review and consider the findings and a vote will be held to determine whether or not to send the survey to member schools.

## HEARINGS

### **Shannon Huffman - Barrington High School** **Article 7, Section 7C1 - Non-School Competition**

Mr. Lynch presented this request as submitted in writing by Barrington High School. The student-athlete, who is entering her senior year, is requesting permission to participate as an individual a one-time weekend girls' soccer event during the high school soccer season.

On a motion made and seconded, the Principals Committee on Athletics voted 10-0, with 1 abstention, to *grant* the request.

### **David Randolph - Barrington High School** **Article 3, Section 4C - 8-Semester Rule**

This matter was continued from a previous hearing held in June 2002 at which the student-athlete and his parents were present. The [June] hearing was an appeal of an earlier decision by the Waiver Hearing Committee to deny a waiver request of the 8-Semester Rule. This waiver request is for his senior year [next year 2003-2004].

On a motion made and seconded, the Principals' Committee on Athletics voted 10-1 to *deny* the appeal, thereby upholding the decision of the RIIL Waiver Hearing Committee.

### **Burrillville High School - [Ice] Hockey Alignment**

Representing Burrillville High School at this hearing were Richard Trogisch, Principal; and Shane McConnell, Head Hockey Coach.

On a motion made and seconded, the Principals' Committee on Athletics voted 8-2, with 1 abstention, to *deny* the appeal.

The August meeting of the Principals' Committee on Athletics was adjourned at 5:05 pm.

\* \* \* \* \*

The September meeting of the Principals' Committee on Athletics was called to order at 1:45 pm

## EXECUTIVE DIRECTOR'S REPORT

The Executive Director's Report was approved.

## TREASURER'S REPORT

The Treasurer's Report was approved.

## RECOGNITION AWARD

A Recognition Award was presented to Victor Mercurio, who resigned in June 2002 as the Director of Boys Soccer. On behalf of the Principals' Committee on Athletics, Mrs. Crowley, Chairperson, expressed her appreciation for his dedication and commitment to the RIIL and the Principals' Committee on Athletics. It was further noted that Mr. Mercurio has agreed to continue to oversee the boys soccer program until a new Director is appointed.

## APPOINTMENT OF NEW MEMBERS

A proposal was made that Emmett (Bob) Cooney, Assistant Principal, Cranston High School East, be appointed to the Principals' Committee on Athletics as Co-Director of Boys' Basketball.

On a motion made and seconded, the Principals' Committee on Athletics unanimously approved the appointment of Emmett Cooney to the Committee as Co-Director of Boys' Basketball.

## COMMUNICATIONS

Mr. Lynch referred to several memoranda and publications that were placed in member's folders or filed in the League office.

## FOOTBALL

### **Mr. James Murano**

Mr. Murano reported that Coventry High School has withdrawn from the RIIL Freshman Football League due to budget constraints. This has resulted in a revised schedule with two (2) divisions of ten (10) teams each, and an expanded playoff format. A notice has been sent to all participating schools informing them of this change.

## SOCCER

### **Mrs. Kathryn Crowley**

Mr. Lynch referred to a request from Chariho High School to waive the (\$50.00) fine for missing the girls soccer coaches interpretation meeting. It was noted that the coach's son had been rushed to the hospital and that it was too late to send a replacement to represent the school.

On a motion made and seconded, the Principals' Committee on Athletics unanimously voted to grant the request to waive the fine.

Mr. Lynch reported on a situation in girls' soccer whereby a student-athlete from Lincoln High School was ejected from a game (last season). Initially, it was reported that the ejection took place in the last game of the 2001-2002 season, which would have resulted in a penalty of being ineligible for the first two (2) games of this season. However, the student-athlete had already played in two (2) games this season before the ejection/penalty surfaced. In accordance with the RIIL Rules and Regulations, Lincoln H.S. should forfeit the two (2) games in which the student played as an ineligible athlete.

However, at this meeting, the student-athlete, her mother, and the athletic director of Lincoln H.S., Kevin McNamara, appeared and presented documentation to verify that the

ejection was not in the last game of the season and that there were still two (2) games remaining in the season. Consequently, the student-athlete satisfied the penalty by sitting out the next League game at the end of [last] season.

Therefore, there was no further penalties imposed and the student-athlete was rendered immediately eligible to participate in girls' soccer at Lincoln High School.

In other business, Mr. Lynch reported on requests from students seeking permission to participate on a select team in a one-time weekend girls' soccer event during the high school soccer season. As stated in the letters, participation in this event would not conflict with their obligations to their school team.

On a motion made and seconded, the Principals Committee on Athletics unanimously approved the requests for Valerie Grow, Cumberland High School, and Kara McDonough, Barrington, High School, to participate in the Washington Area Girls Soccer (WAGS) Tournament in Washington, DC on the Columbus Day Weekend.

#### **TENNIS**

**Mrs. Denise Boulé  
Ms. Candace Caluori**

Mrs. Boulé reported that Woonsocket High School postponed the first scheduled match of the season to later in the season because of a change in the coaching staff.

#### **VOLLEYBALL**

**Mr. Donald Kavanagh  
Ms. Elaine Botelho**

There was no Volleyball report at this meeting.

#### **LACROSSE**

**Mr. George Finn**

Mr. Finn reported that he is awaiting word of whether teams will be participating for the 2002-2003 school year as a member of the RIIL lacrosse league or as members of non-school clubs. It was noted that schools need the approval of their respective School Committees/Districts to join the RIIL boys and/or girls lacrosse league.

#### **BASKETBALL**

**Mr. Gerald Foley  
Ms. Cindy Neal  
Ms. Colleen Gribbin**

Mr. Lynch reported that Cindy Neal, Director of RIIL Girls Basketball, has been selected into the inaugural class of inductees of the New England Basketball Hall of Fame. The induction ceremonies will take place on Friday, October 4, 2002. On behalf of the Committee on Athletics and the RIIL staff, Mr. Lynch extended his congratulations to Ms. Neal for being a recipient of this prestigious honor.

Ms. Gribbin submitted the 2002-2003 [boys and girls] freshman basketball schedules for the Committee's review and consideration. She stated that the [Freshman Basketball] Coaches Interpretation Meeting is scheduled for Thursday, November 7, 2002, at the RIIL Office. The girls' coaches will meet at 6:00 pm, followed by the boys' coaches at 7:00 pm.

On a motion made and seconded, the Principals' Committee on Athletics unanimously approved the 2002-2003 boys and girls freshman basketball schedules.

In other business, Mr. Lynch reported on the R. I. Basketball Officials' Association's proposal whereby they want to be paid for officiating boys and girls Injury Fund basketball games and will make a single donation from the Association to the Fund. Representatives of the Injury Fund maintain that it was never intended that officials would be paid for injury fund games. They further maintained that the injury fund never wanted expenses taken from the Athletic Directors' regular budget to fund injury fund games. Therefore, if officials want to be paid for working these games, the R. I. Interscholastic Injury Fund will cancel [basketball] injury fund games and designate that each school pass the hat at its first home game and make a donation to the Injury Fund. Negotiations between the R. I. Injury Fund and the R. I. Basketball Officials' Association continue. Mr. Lynch will report any findings to the Committee at its next meeting.

Mr. Lynch also reported on requests submitted to the League office from Cumberland High School and Rhode Island College to host their respective holiday girls' basketball tournaments. The requests sought a waiver of the rule, which states that no contests shall be scheduled/played prior to the Injury Fund game(s). It was noted that the proposed dates for the tournaments (Cumberland - Nov. 29-30, and RIC - Nov 30-Dec 1) would not allow sufficient time for the student-athletes to meet the required ten (10) practice/conditioning days as mandated by the RIIL Rules and Regulations. This is due in part to the fact that the Thanksgiving Day holiday falls within the time period between the first day of authorized practice (November 20<sup>th</sup>) and the proposed tournament dates. On a vote of 7-0, with 2 abstentions, the Principals' Committee on Athletics approved the requests to host tournaments before the Injury Fund game(s). However, the approval is with the stipulation that the dates be changed to allow the students to meet the ten (10) day practice/conditioning requirement.

#### **INDOOR TRACK**

**Ms. Jane Headley  
Mr. Charles Sweeney**

The 2002-2003 Girls' and Boys' Indoor Track Schedules were submitted for the Committee's review and consideration.

On a motion made and seconded, the Principal's Committee on Athletics unanimously approved the 2002-2003 girls' and boys' indoor track schedules.

#### **GYMNASTICS**

**Mr. Richard Stapleton  
Ms. Melissa Gendreau**

Mr. Stapleton submitted the 2002-2003 Gymnastics Schedule for the Committee's review and consideration.

On a motion made and seconded, the Principal's Committee on Athletics unanimously approved the 2002-2003 gymnastics schedule.

In other business, Mr. Stapleton submitted several issues from the Gymnastics Coaches Association, including, but not limited to, a proposed change in the playoff format. A length

discussion ensued and it was recommended that Mr. Lynch and Mr. Magarian meet with representatives from the gymnastics coaches' and officials' association to review the recommendations. The matter was tabled to the October meeting of the Principals' Committee on Athletics, at which time Mr. Lynch will report his findings.

#### **FIELD HOCKEY**

**Ms. Jean Angell**

Ms. Angell reported that plans are underway to hold the playoffs at Bryant College. She suggested that the facilities at North Kingstown High School be used as a possible 'back-up' in the event that Bryant College is not available.

#### **SWIMMING**

Mr. Lynch reported that James Quinn has submitted his letter of resignation as the Director of Boys and Girls Swimming. On a motion made and seconded, the Principals' Committee on Athletics accepted, with regret, Mr. Quinn's resignation.

A proposal was made that Kenneth Reall be appointed as Director of Boys' and Girls' Swimming. It was noted that Mr. Reall served in this capacity prior to Mr. Quinn's tenure as Director of Swimming.

On a motion made and seconded, the Principals' Committee on Athletics unanimously approved the appointment of Kenneth Reall as Director of Boys' and Girls' Swimming.

In other business, the 2002-2003 Boys' and Girls' Swimming Schedule was submitted for the Committee's review and consideration.

On a motion made and seconded, the Principals' Committee on Athletics unanimously approved the 2002-2003 Boys' and Girls' Swimming Schedule.

#### **HOCKEY**

**Mr. Daniel Sheehan**

Mr. Sheehan reported that several ice rinks have changed their [ice time] availability by taking back dates that were originally available. Consequently, there are some problems with developing the 2002-2003 [boys'] schedule. Insofar as it is necessary to distribute the schedule as soon as possible to participating schools and all rinks, Mr. Sheehan sought approval from the Committee to send out the schedule once it has been completed, rather than again bring it before the Committee at its October meeting.

On a motion made and seconded, the Principals' Committee on Athletics unanimously approved Mr. Sheehan's request to send out the 2002-2003 boys' hockey schedule as soon as it has been completed.

Mr. Sheehan also reported that the newly formed RIIL girls' hockey league will have an eight (8) game schedule. Each team will play the other teams twice during the season. It was agreed that, because this is the first year for girls' hockey, there will not be a separate injury fund event for the girls. Rather, a collection will be taken at a designated League game and donated to the Injury Fund.

In other business, Mr. Lynch submitted the 2001-2002 Hockey Financial Report for the Committee's review and

consideration. However, during the ensuing discussion, an error was found. Therefore, Mr. Lynch will correct the report and submit the amended report to the Committee at its October meeting.

#### **NATIONAL SCOUTING REPORT**

Mr. Lynch reported on a proposal submitted by the National Scouting Report [Providence, RI], an organization whose mission is 'to identify high school students that are both academically and athletically strong and have a desire to participate at the college level'. The proposal states that representatives from the National Scouting Report would visit all Rhode Island high schools and compile an information package for interested student-athletes that would make them more 'marketable' to colleges. They also want to set up a table at all RIIL championship events.

During the ensuing discussion, Committee members expressed their concern about the representatives from National Scouting Report intruding on school time and requesting information from schools, that would put a burden on the schools' staffs. They also expressed concerns about granting permission to one scouting organization over another.

On a vote of 9-0, the Principals Committee on Athletics unanimously denied the proposal.

#### **RIIL 2001-2002 ATHLETIC PARTICIPATION SURVEY**

Mr. Magarian referred to a copy of the survey that had been placed in each member's folder. He stated that, during the last two (2) years, there is a slight increase in the number of boys and girls participating in interscholastic athletics. For the 2001-2002 school year, there was a total of 14,277 boys and 10,095 girls participating in Rhode Island high school interscholastic athletics. Mr. Magarian also noted that these figures [also] include those students that participate in more than one sport.

#### **ALTERNATIVE EDUCATION SCHOOL(S)**

- **Blackstone Academy - Pawtucket, RI**  
Blackstone Academy is a charter school, Grades 9-12. They are requesting athletic eligibility for their students to participate in athletics for their [feeder] schools of residence - Central Falls, Shea, and Tolman High Schools.

On a vote of 9-0, the Principals' Committee on Athletics unanimously approved the request.

- **The Met School - Providence, RI**  
The Met School is a charter school, Grades 9-12. They are requesting athletic eligibility for Kandakai Duncan, a student enrolled in Grade 10 at The Met School, to participate in football, basketball and baseball at Hope High School, his school of residence.

On a vote of 9-0, the Principals' Committee on Athletics unanimously approved the request.

#### **ELIGIBILITY LISTS**

Mr. Lynch submitted a list of several schools that did not submit eligibility lists or submitted them late. In accordance

with the RIIL Rules and Regulations, eligibility lists must be submitted online prior to the first contest in any given sport, including the Injury Fund contest. The missing and/or late lists were for several different sports.

On a vote of 9-0, the Principals' Committee on Athletics voted to impose a \$200.00 fine per school/per list for each list not submitted in accordance with the rules.

#### ELIGIBILITY FOR FOREIGN EXCHANGE STUDENTS

##### • **The Lincoln School**

Seeking athletic eligibility for a Foreign Exchange Student who is here independently and not with an authorized Foreign Exchange Program.

On a vote of 8-1, the Principals Committee on Athletics approved the request.

##### • **Chariho High School - Madli Kuseok**

Seeking athletic eligibility for a Foreign Exchange Student who is here independently and not with an authorized Foreign Exchange Program.

On a vote of 8-0, with 1 abstention, the Principals Committee on Athletics approved the request.

##### • **Chariho High School - Franziska Zipp**

Foreign Exchange Student seeking athletic eligibility. The Foreign Exchange Program, under which she is in the U.S.A., is an authorized program. However, it was indicated on the RIIL Foreign Exchange Student Data Form that she a) completed her course of study in her home country; and, b) athletics was a consideration when selecting the (American) school. In accordance with the RIIL Rules and Regulations, this renders her ineligible to participate in interscholastic athletics. A letter was sent to Robert Mitchell, Principal of Chariho High School, notifying him that the student was not eligible. He subsequently appealed the decision, stating that the student misunderstood the items on the form and, therefore, completed the form incorrectly.

On a vote of 6-3, the Principals' Committee on Athletics denied the appeal and requested that Chariho High School submit more detailed information regarding this student; i.e., what sport did she play in her home country, did she 'graduate' in her home country, etc.

Discussion continued regarding eligibility for foreign exchange students and the RIIL Foreign Exchange Student Data Form they are required to complete and submit. The Committee believes that the form does not request detailed information that would allow the RIIL and/or Committee to make an informed decision. They believe that foreign exchange students should be held to the same [high] standards/eligibility requirements as those to which students enrolled in member schools are expected to adhere to.

Subsequently, the Committee asked that the League staff review the existing Foreign Exchange Student Data Form and revise it to include more thorough information. Mr. Lynch will submit a revised form to the Committee at its October meeting.

#### HEARINGS

##### • **Russell Hines - North Kingstown High School**

Background: This is an appeal of a decision by the Waiver Hearing Committee on August 27, 2002, which denied a request for a waiver of Article 3, Section 5 - the Transfer Rule. Present for this hearing were Gerald Foley, Principal, North Kingstown High School; Mrs. Ann Hines, student's mother; and Russell Hines, student-athlete.

On a vote of 5-1, the Principals' Committee on Athletics *denied* the request.

The September meeting of the Principals' Committee on Athletics was adjourned at 5:05 pm.



**DIMENSIONS FOR  
POLE VAULT LANDING SYSTEM**

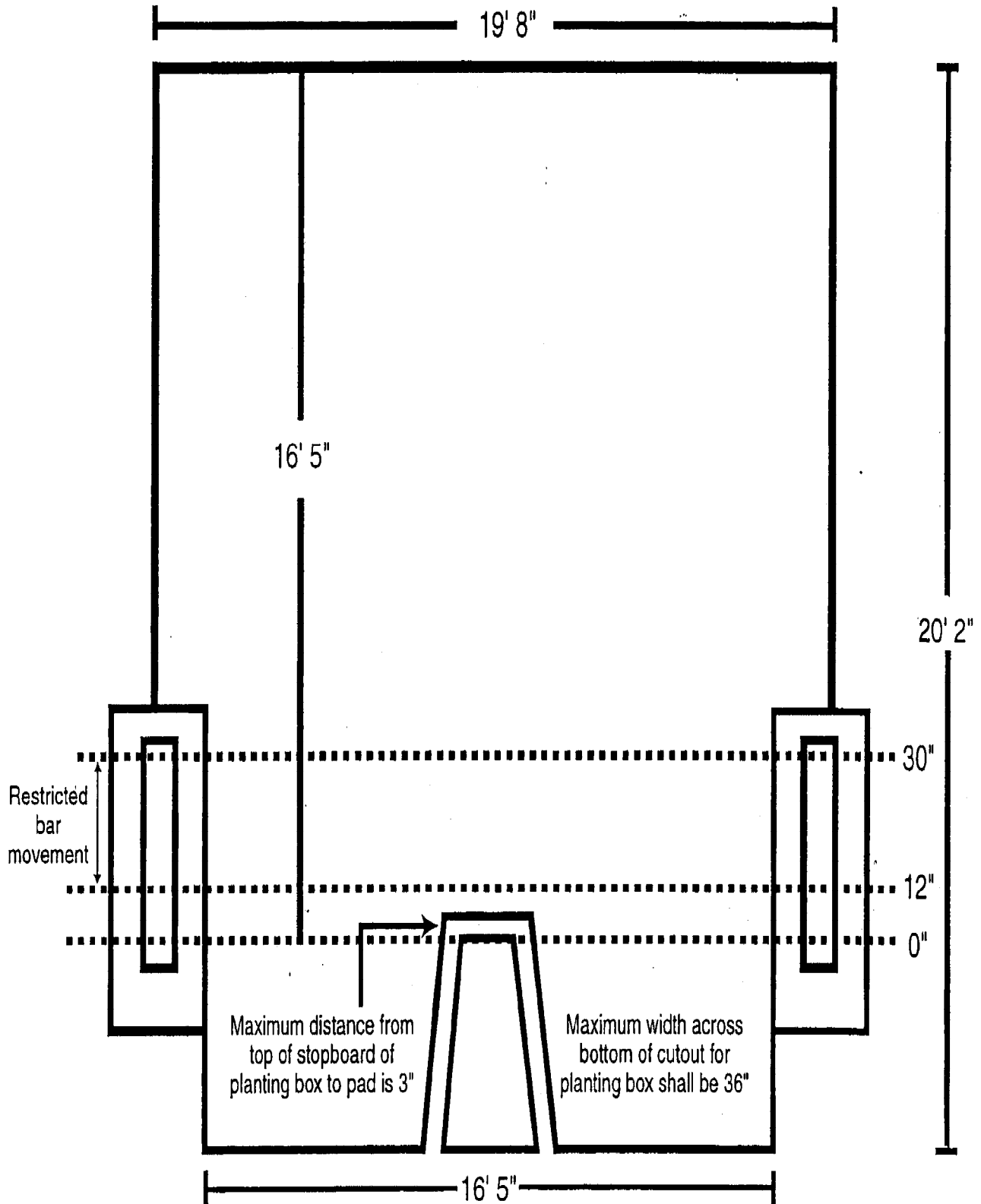

**The RIIL is Proud to Recognize  
its Corporate Sponsors**

**BADEN ATHLETIC BALLS**

**BOB'S STORES**

**BRINE**

**BLUE CROSS & BLUE SHEILD OF RHODE ISLAND**

**EMPIRE CORPORATE FEDERAL CREDIT UNION**

**LEGG MASON**

**METLIFE AUTO AND HOME**

**PEPSI COLA Co.**

**THE PAWTUCKET RED SOX**

**PENN MONTTO**

**RAWLINGS SPORTING GOODS**

**SPALDING**

**UNITED STATES AIR FORCE**

